

thermomix

VORWERK

Sensor

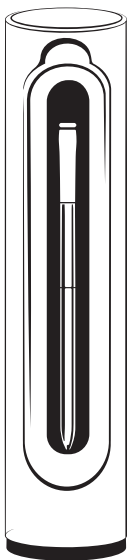

User manual

AU NZ • V1.0 • 27448 09/23

Table of Contents

1	Before You Start.....	3
1.1	Classification of Safety Warning Messages.....	4
1.2	Obligations of the User.....	4
2	Product Overview	5
3	Intended Use.....	5
4	For Your Safety	7
4.1	Hazards and Safety Instructions.....	7
4.2	Selection of the Core Temperature ..	12
5	Getting started.....	12
6	Establishing a Bluetooth® Connection	13
7	Operation	14
7.1	Switching on and off	14
7.2	Design of the probe	14
7.3	Inserting the probe into food being cooked	14
7.4	Positioning the probe and charger...	16
7.5	Cooking with the probe.....	17
8	Cleaning	17
9	Troubleshooting.....	17
10	Customer Service Australia / New Zealand	18
11	Warranty/Liability for Material Defects	18
12	Disposal.....	19
13	Technical data	20

1 Before You Start

As a Thermomix® user, you are already familiar with the Thermomix® TM6 and its accessories.

You have already familiarised yourself with the safety features of the Thermomix® Sensor by reading the printed **General Product Information** booklet enclosed with the Thermomix® Sensor.

This **user manual** will now familiarise you with the use of the Thermomix® Sensor.

Read all accompanying documents carefully before using the Thermomix® Sensor for the first time.

You must also read and observe the user manual for the Thermomix® TM6, which was supplied with the device.

If you do not have the user manual to hand, all manuals are available online at <https://thermomix.vorwerk.com>.

Welcome booklet

Read our digital welcome booklet for even more inspiration and tips on using the Thermomix® Sensor. It also contains troubleshooting information, FAQs and helpful tips on how to use the Thermomix® Sensor correctly.

AU/NZ

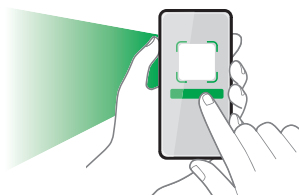

1.1 Classification of Safety Warning Messages

The safety warning messages in this manual are highlighted by safety symbols and signal words. The symbol and signal word indicate the severity of the potential hazard.

Classification of Safety Warning Messages

The safety warning messages that precede each action are shown as follows:



Type and source of hazard.

Explanation of type and source of hazard / consequences

- Measures to prevent hazard

Meaning of signal words

HAZARD	Risk of death or serious injury if hazard is not avoided.
CAUTION	Risk of minor injury if hazard is not avoided.
NOTE	Damage to property or equipment if hazard is not avoided.

1.2 Obligations of the User

To ensure that your Vorwerk appliance and accessories operate correctly, please follow the guidelines below:

1. Please read all accompanying documents carefully.
2. Keep the provided documents in a place where it can easily be accessed, should you need to refer to it.
3. Ensure that any damage is repaired or damaged parts are replaced by a Thermomix® customer service centre without delay. Contact [Customer Service Australia / New Zealand](#) [▶ page 18] for further assistance.

2 Product Overview

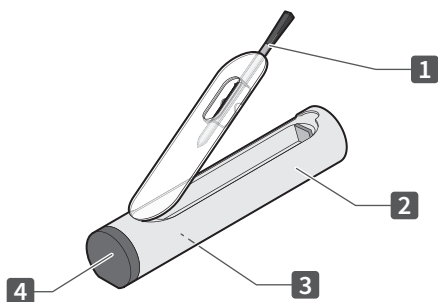

1 Probe

3 Battery compartment (on reverse of the charger)

2 Charger

4 Holder

3 Intended Use

Use the device and accessories only for their intended purpose in order to prevent risks to you and other people and to prevent damage to the device and accessories or to other property and equipment.

Thermomix® Sensor is an accessory for Thermomix® TM6. It measures the core temperature of food and is suitable for use in the home or similar environments.

The probe must only be used with food.

The ambient temperature sensor, which measures the ambient temperature, i.e. the temperature in the oven or grill, is located in the top section of the probe. The ambient temperature must **never** exceed 275°C.

The core temperature sensor is located approx. 2 cm away from the tip and measures the core temperature of the food. The core temperature is the temperature inside the food. This part of the probe must never exceed 100°C.

The probe is intended for measuring the temperature of food in standard ovens. Use in combination microwave ovens is not always possible due to the heavy shielding of these ovens. Do not use the probe with microwave function in such ovens.

Store the probe in its charger in a cool, dry place when not in use.

This accessory is exclusively intended for use by adults. It must not be used by children even when supervised by an adult.

Keep children away from appliances that are in use.

Close supervision is necessary when this accessory is used near children.

Children must not play with this accessory.

The accessory may be used by persons with reduced physical, sensory or mental capabilities, or lack of experience and/or knowledge, only if they are supervised or instructed with regard to the safe use of the appliance and understand the resulting hazards.

This appliance may only be used for its intended purpose. No other use is permitted.

The product complies with the safety regulations of the country in which it has been sold by an authorised Vorwerk organisation. If the product is used in another country, compliance with the local safety standards cannot be guaranteed. Vorwerk therefore assumes no liability for any resulting safety risks for the user.

When working with the product, please observe all the accompanying documentation as well as the device and accessory display.

4 For Your Safety

Safety is an essential part of every Vorwerk product. However, product safety can only be ensured if this chapter and the warning notices elsewhere in this User Manual are followed.

4.1 Hazards and Safety Instructions



WARNING

Explosion hazard

If the rechargeable batteries built into the tip of the probe are exposed to high heat levels (> 100°C), the probe could explode. Therefore:

- Insert the probe into the food away from any heat sources and only remove it once the food and probe are no longer exposed to the heat source.
- Always insert the probe into food beyond the notch. The only exception to this rule are foods that significantly increase in size, including but not limited to cake doughs and batters. In such cases, the notch may be uncovered to start with, but will then become covered during the course of the bake.
- Make sure that the probe is securely in place and does not move out of position.
- Do not use as a thermometer for sugar based food (e.g. caramel) as there a significantly higher temperature is used.

Explosion hazard

When the batteries built into the probe overheat, the probe could explode.

- Use the probe at a maximum ambient temperature of 275°C.
- **Never** put the probe onto a fire or hot coals.
- Never expose the probe to direct flames.
- Do not use the probe while deep frying or on a very high heat (e.g. sizzle zone or sear zone).
- **Never** use the probe with microwave function or pressure cooker.
- If, however, the probe does become exposed to high temperatures, protect your eyes before you remove the probe and carefully allow it to cool down.
- If the probe falls onto a fire or a direct heat source, switch off the cooking appliance or grill and immediately put the lid on. Allow the probe to cool completely before taking it out.

Explosion hazard

The charger, and in particular the battery supplied with it, are not heat-resistant.

- Do not expose the battery and charger to heat sources, including open fires, or place them on hot surfaces.
- Use the magnetic holder only on cool, heat-insulated oven doors.

Explosion hazard

If a battery falls onto the floor, is thrown or subjected to other heavy knocks, the battery's insulating shell or structure can get damaged, which can result in leakage, an internal short circuit or other anomalies. An internal short circuit can cause overheating, leakage, an explosion or a fire.

- Handle the battery with care.

Risk of burns

When used at high ambient temperatures, the probe and food will heat up.

- Never touch the probe with bare hands when hot.
- Protect yourself against burns by using heat-resistant gloves, oven cloths or the holder if touching the hot probe or the oven or grill, etc.

Fire hazard

If incorrect batteries are used, mechanical overload (dropping the charger) can result in a fire.

- Only use non-rechargeable alkaline batteries of type LR03, AAA, 1.5V cell (1.5V primary cell).
- Handle the charger with care.

Risk to health

The consumption of insufficiently cooked food (especially meat, fish or seafood) can cause food poisoning.

- Please also refer to the section on [Selection of the Core Temperature](#) [▶ page 12].
- Make sure the tip of the probe is inserted as close to the centre of the thickest part of the food as possible, without touching the bone or tin.
- Handle food and the areas that come into contact with food carefully and clean them thoroughly (including hands and probe) to prevent the spread of germs.

Risk to health

The holder is only food-safe up to 220°C.

- Never use the holder at ambient temperatures above 220°C.

Risk of injury

Broken ceramic can have sharp edges and cause injury.

- Check the probe for damage when inserting it and removing it from food.
- Do not continue to use the probe if it is broken.
- Protect yourself from sharp-edged fragments.
- If the probe has been dropped, check it for damage before charging or using it.

Risk of injury

The tip of the probe is pointed and sharp.

- Keep the tip of the probe away from the body.
- Clean the probe after use to avoid the risk of germs in the event of an injury.
- Keep the probe out of the reach of children.

Risk of contact with dangerous substances

Leaked electrolyte from batteries and rechargeable batteries can cause injuries.

- Do not touch leaked electrolytes or electrolyte residues from leaking batteries or rechargeable batteries without skin or eye protection.
- Leaking electrolytes must not come into contact with skin, eyes or mucous membranes.
- In case of accidental contact, immediately wash your hands and flush the eyes or mucous membranes with plenty of clean water.
- If irritation persists or the electrolyte has come into contact with the eyes or mucous membranes, seek medical advice.
- Clothing and textiles that have come into contact with leaked electrolyte or electrolyte residues must be thoroughly washed immediately or disposed of.
- Leaked electrolyte, electrolyte residues, as well as leaking batteries and rechargeable batteries, are flammable. Keep them away from fire and heat.

Risk of contact with dangerous substances

Leaked electrolyte in food can cause injuries.

- If the batteries have exploded or leaked, do not consume the food that has been cooked.

Choking hazard

Small parts may enter the airways and cause choking.

- The AAA battery used in the charger is a small part. Keep small parts out of the reach of children.

Risk due to magnetism

Magnets are fitted to the outer surface of the charger. Magnets can affect pacemakers and internal defibrillators.

- Keep the magnet away from pacemakers, internal defibrillators and other active implants.
- Alert the people concerned.

Risk of fire or explosion

Charging non-rechargeable batteries can cause a fire or explosion.

- Only use non-rechargeable alkaline batteries of type LR03, AAA, 1.5V cell (1.5V primary cell).



NOTICE

Risk of damage

The charger can get damaged if handled incorrectly.

- Only place the probe into the charger once it has cooled down and is clean and dry.

Risk of damage

The probe can get damaged if handled incorrectly.

- Allow the probe to cool down to room temperature before cleaning it with water in accordance with the cleaning instructions.
- If the probe is difficult to remove, pull and rotate the outer end.
- Do **not** bend the probe.
- Handle the probe with care.

Risk of damage

The probe can get damaged if used incorrectly.

- Do **not** exceed 100°C in the area around the core temperature sensor (2 cm away from the tip).
- Do **not** exceed 275°C around the area of the ambient temperature sensor. Temperatures above these maximum values can damage the probe.
- To ensure the safety of the probe, Thermomix® TM6 and Cooking Centre app will warn you when you are approaching these limits.

Risk of damage

The device and accessories can get damaged if not cleaned correctly.

- Do **not** use cleaning products that contain alcohol, ammonia, benzene or abrasives as these could damage the device and the accessory.
- Do **not** immerse the probe in water for long periods of time.

Risk of damage to the charger

Moisture inside the charger can damage it.

- Never pour water over the charger.
- Do not hold the charger under running water.
- Never immerse the charger in water or other liquids.
- Only clean the charger with a slightly damp (not wet) cloth.
- Do not expose the charger to moisture.
- Keep the charger covered in inclement weather.
- Do not put the charger in the sink.
- Do not store the charger outdoors.

Risk of damage due to magnetism

Magnets are fitted to the outer surface of the charger.

- Keep credit cards, electronic storage media and other objects that are sensitive to magnetic fields away from them.

4.2 Selection of the Core Temperature

When selecting the core temperature, the quality of the food, the safe handling of the food and the maintenance of the cold chain must be taken into consideration. Safe core temperatures are particularly important for people with weakened immune systems, including pregnant women, children and the elderly.

5 Getting started

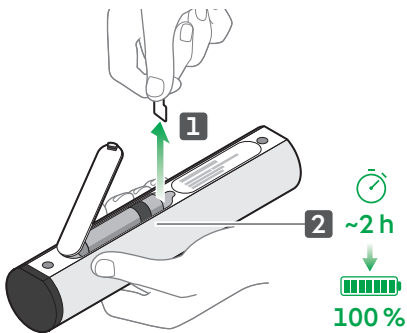

1. Open the battery compartment at the back of the charger and remove the protective film.

2. Allow the probe to charge for approx. 2 hours in the charger with the cover closed.



3. Download the app.

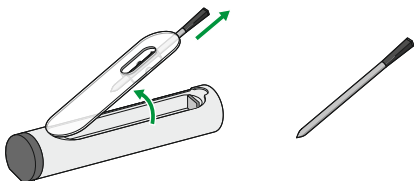

4. Remove the probe from the charger.
⇒ *The LED will flash green to indicate that the probe and charger are connected.*
5. Clean the probe with water and washing-up liquid to remove any production residues before using it for the first time.

6 Establishing a Bluetooth® Connection

Thermomix® TM6	Cooking Centre app
Activate the Bluetooth® function under <i>Settings</i> on Thermomix® TM6.	Make sure that Bluetooth® is enabled on your mobile device.
Remove the probe from the charger. Pairing mode is enabled.	
On Thermomix® TM6, select the probe from the list under <i>Settings > Connected devices</i> .	Press + in the app to select the probe from the list under <i>Select devices</i> .

The probe will now connect automatically as soon as it is removed from the charger and Bluetooth® is enabled on the paired devices.

7 Operation

7.1 Switching on and off

When you take the probe out of the charger, it will automatically start up.

To switch the probe off, put it back into the charger and close the cover.

7.2 Design of the probe

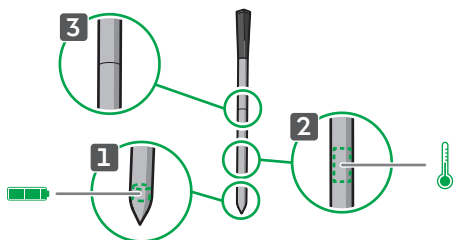

1. The battery is located in the tip of the probe (1). Here, it is best protected from high temperatures.
2. The temperature sensor (2) is located 2cm away from the tip. Position this part of the probe as close to the centre of the food as possible when measuring the core temperature.
3. The notch (3) indicates how far the probe must be inserted into the food.

7.3 Inserting the probe into food being cooked

To insert the probe into the food, proceed as follows:

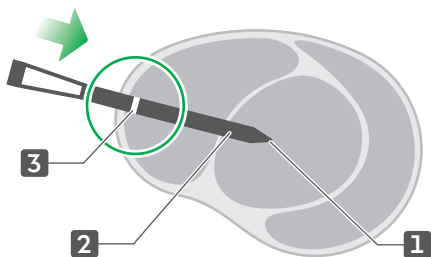

1. Insert the tip (1) of the probe into the food.

- The temperature sensor (2), which measures the core temperature, is located 2cm behind the tip. Position this part of the probe as close to the centre of the food as possible.
- The notch (3) will disappear into the food as you do so. This will ensure that the temperature sensor can correctly measure the internal temperature of the food.

Using the holder

If the probe does not have a sufficiently firm hold in the food (for example, a cake batter or dough with a thinner consistency), you can attach the probe to the baking tin using the holder to ensure that the probe does not slide out. You can choose between two different insertion angles, A and B, depending on the size of the baking tin. Only use the holder up to a maximum temperature of 220°C.

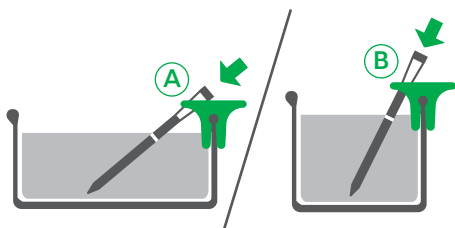

For food that may expand during cooking, like dough or batter/cake mix, the insertion depth of the probe may vary.

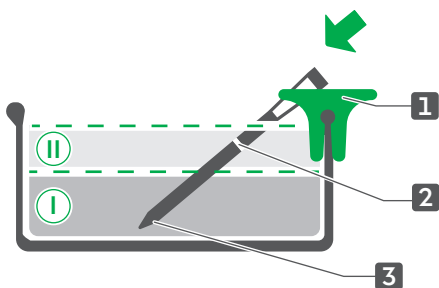

I Dough fill level before baking: The probe is inserted at least halfway between the tip (3) and notch (2). The notch will be visible.

II During baking, the dough rises: The notch (2) is covered.

- Place the holder (1) onto the edge of the baking tin.

2. Depending on the preferred angle, select opening A or B and slide the probe through the holder and into the food.
3. Make sure that the tip of the probe (3) does not touch the baking tin.

7.4 Positioning the probe and charger

During the cooking process, the probe continually measures the core temperature and ambient temperature. The probe sends this data to the charger. This transfers the data to the Thermomix® TM6 or Cooking Center app. It acts as a repeater and amplifies the signal.

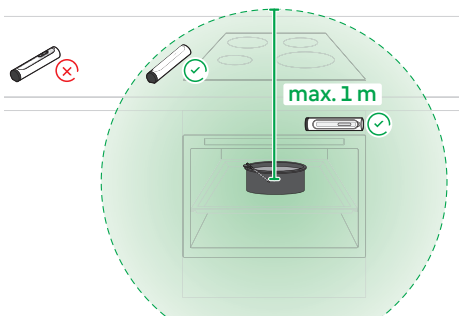

1. Therefore, place the charger at a maximum distance of 1 metre from the probe. Depending on the shielding of the Bluetooth signal by e.g. the oven door, a smaller distance may also be required.
The Thermomix® TM6 or Cooking Center app can be further away from the probe and its charger.
2. Place the charger on a cold surface.
You can attach the charger with the magnets to the oven front if it remains cold during the baking process.
Alternatively, place the charger nearby on the countertop.

When the charger is connected to the probe, the LED of the charger flashes green.

If there is no connection, the LED flashes red. In this case, position the charger closer to the probe.

7.5 Cooking with the probe

During the cooking process, the probe is permanently connected to the Cooking Centre on your Thermomix® TM6 and/or with the Cooking Centre app. This means that you receive information on the temperature and remaining cooking time.

- Follow the instructions on the display.

8 Cleaning

1. Clean the probe with water and washing-up liquid **before first use** and **after** every subsequent use.
2. Make sure that the probe is clean and completely dry before putting it back in the charger. Thorough cleaning will ensure that the probe can be charged.

9 Troubleshooting

AU/NZ

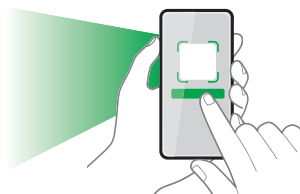

10 Customer Service Australia / New Zealand

The Mix Australia – Vorwerk Official Distributor

30 Ledger Road, Balcatta WA 6021

International: +61 8 92766966

Local free call: 1800 004 838

Contact Us: thermomix.com.au/contact-us

The Mix New Zealand – Vorwerk Official Distributor

International: +64 3 366 2846

Local free call: 0800 766 966

Contact Us: thermomix.co.nz/contact-us

For details of your local customer service centre please contact your Thermomix® consultant, the Vorwerk Official Distributor in your country, or refer to <https://thermomix.vorwerk.com>

This instruction manual is available in other languages at

<https://thermomix.vorwerk.com>

11 Warranty/Liability for Material Defects

The Thermomix® and the accessory may only be repaired by a Thermomix® customer service centre (or persons authorised by Thermomix®).

Only use original parts supplied with the Thermomix® or original spare parts from Vorwerk. Never use the Thermomix® in combination with parts or equipment which have not been provided by Vorwerk. Failure to observe these instructions may void your warranty.

For the terms and conditions of your warranty, please refer to the terms and conditions of your purchase contract.

12 Disposal



This symbol means that electrical and electronic devices or accessories may not be disposed of in the normal household waste. Old electronic appliances can be returned to municipal collection points for free. Alternatively, you are able to return old electronic devices or accessories to your local supplier of Vorwerk products.

Registration number:
WEEE Reg. No. DE 86265910

13 Technical data

Thermomix® Sensor

Probe (TSNP)

Rated voltage of probe	2.4V
Capacity of probe	3mAh
Operating times	approx. 24 hours
Charge time	approx. 2 hours

Charger (TSNC)

Alkaline battery	AAA
Rated voltage of battery	1.5V
Operating temperature of charger	-5°C– 60°C

Information on Bluetooth® connectivity

2.4 GHz
2.402 GHz – 2.480 GHz
< 5 dBm
Bluetooth® 5.0 Low Energy

The Bluetooth® word mark and logos are registered trademarks owned by Bluetooth SIG, Inc. Any use of these word marks and logos by Vorwerk Elektrowerke GmbH & Co. KG is under licence.

Declaration of conformity

Vorwerk Elektrowerke GmbH & Co. KG hereby declares that the radio equipment type Thermomix® Sensor is in compliance with the Directive 2014/53/EU.

The full text of the EU declaration of conformity is available online at the following address: <https://www.vorwerk-group.com/en/home/meta/ec-declaration-of-conformity>

Vorwerk Elektrowerke GmbH & Co. KG
Mühlenweg 17-37
42270 Wuppertal, Germany

thermomix

